

Pop-up flight

Technical Manual

Table of Contents

Introduction	3
How does it work?	3
Activation of flights.	4
Belt scraper.	5
Driving the belt.	6
Sprocket engagement	7
Retainer Rings	7
Guiding the belt	8
Hold down profiles	9
Return belt support	9
Recommended belt sizes.	10
Recommended belt dimensions	10
Hold down tabs	11
Placing of activation and wear strips, plus drive and idler sprockets	12
Positions of activation strips	13
Positions of sprockets	14
Materials for the Pop-up flight system	15
Further support	15

Introduction

The purpose of this Pop-up flight Engineering Guide is to give support to design of conveyors and how best to utilize the unique features of this belt series. This guide will give advice to issues that need to be considered to maximize the benefits of uni Pop-up flight.

Pop-up flight, integrated into modular belt systems, is a mechanical flight that automatically stands when needed, and lies down when it is not. Partnered with discharge belt scraper, it effectively saves labor-intensive cleaning up – of both belts and floors – and makes sure that the product for discharge reaches its intended destination.

The Pop-up flight is exclusively designed for use with the Ammeraal Beltech belt series uni MPB.

How does it work?

Pop-up flights are mainly for inclined transport of sticky products. The Pop-up flights will pop-up when activated by a support strip beneath the Pop-up flight.



At the in-feed belt section **1** the products are either manually loaded or transferred from another conveyor or chute. The flights will under normal circumstances be lying low at this section. The flights when lowered are more impact resistant.

At the incline belt section **2**, the flights are activated and raised, supporting the products during incline conveying.

At the out-feed belt section **3** the flights will be lowered either at the beginning or end of this section. With the flights lowered the transfer gap is minimized and further allows less clearance to the hopper collecting the residual products.

At the upper return section **4**, the flight will be de-activated, which allows a scraper to clean the belt and remove any residual sticky products.

Finally, at the return side section **5** the flights will by gravity pop-up, and when needed allow for cleaning of the flights.

Activation of flights

When the Pop-up flights are not activated they will be lying flat on top of the belt surface on the carry section and on the return section they will just be hanging due to gravity.



The Pop-up flights are lifted by activation strips that are placed directly under the pop-up cam. Beside lifting the flights the activation strips will also function as an belt support wear-strips.

The design of the conveyor will require both wear strip and as well as activation strips. To ensure optimum activation and best possible flight support it is highly recommended that there is installed an activation strip beneath every pop-up cam.

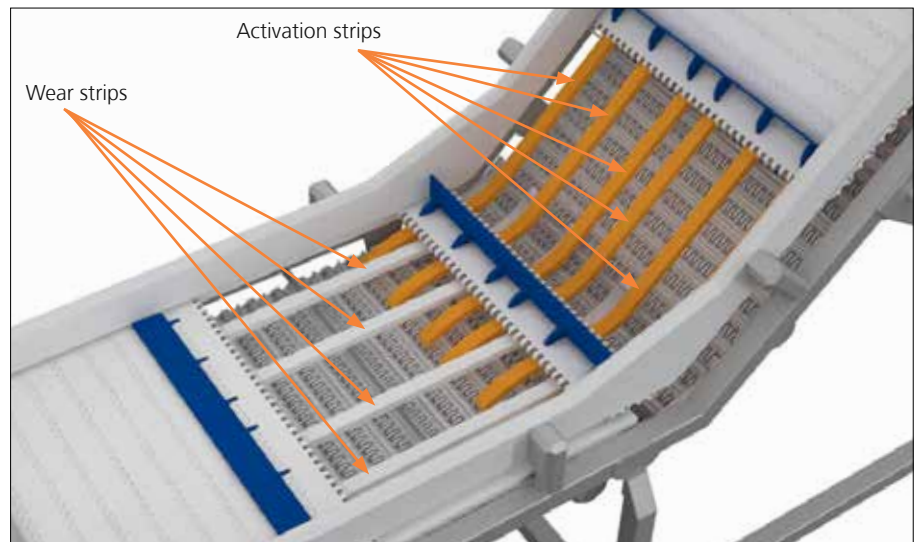

At the conveyor in-feed section the Pop-up flights are not activated and are lying flat on the belt surface, this protects the flights from mechanical damage and prevents products being loading in the area behind the flight.

To empty the conveyor proper, it will for some products be an advantage to have raised flights at the out-feed section.

For details of placing of activation strips, please see table at section "Placing of activation and wear strips, plus drive and idler sprockets".

Belt scraper

One of the main features of the Pop-up flight system is the possible use of a flighted belt with a belt scraper. Belt scrapers can be used to ensure products are correctly removed from the belt surface, thus reducing product carry over and loss on return section of conveyors. In addition belt scrapers can be simply used to aid to transfer of some products to the next conveyor section in a system.

Belt scrapers can be used at any point on the return section but they are normally mounted close to the discharge end. Scrapers can be most effective on the horizontal return section just after the drive sprockets.

Any belt scrapers used must not be fixed but must either be spring loaded or counter-balanced against the belt surface allowing the scraper to move and follow the contact surface profile. The rubbing pressure between scraper and belt should be adjustable and generally set to the lowest effective contact pressure found to remove the products whilst avoiding any wear or marking of surfaces.

During operation the chamfer on the Pop-up flights leading edge lifts the belt scraper. The chamfer is only present on the leading edge of the Pop-up flight so if for any reason the belt needs to travel in the opposite direction any belt scrapers must be first lifted.

- Belt scrapers must pivot or lift, they must not be fixed solid
- Scraper contact pressure against belt should be adjustable
- Ensure belt scrapers are lifted before reversing travel direction
- The use of metal belt scrapers is not recommended

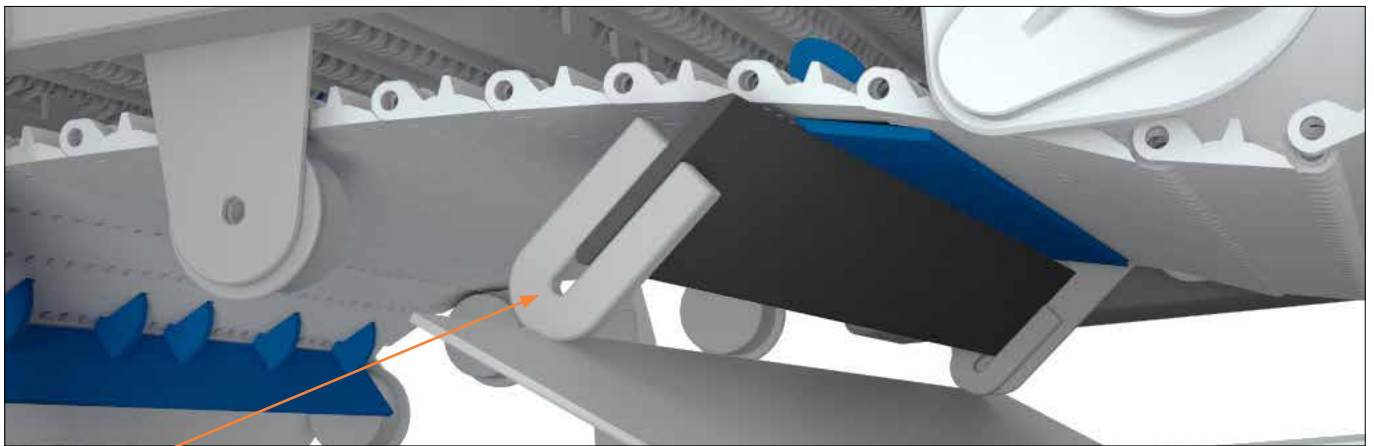

Spring suspension

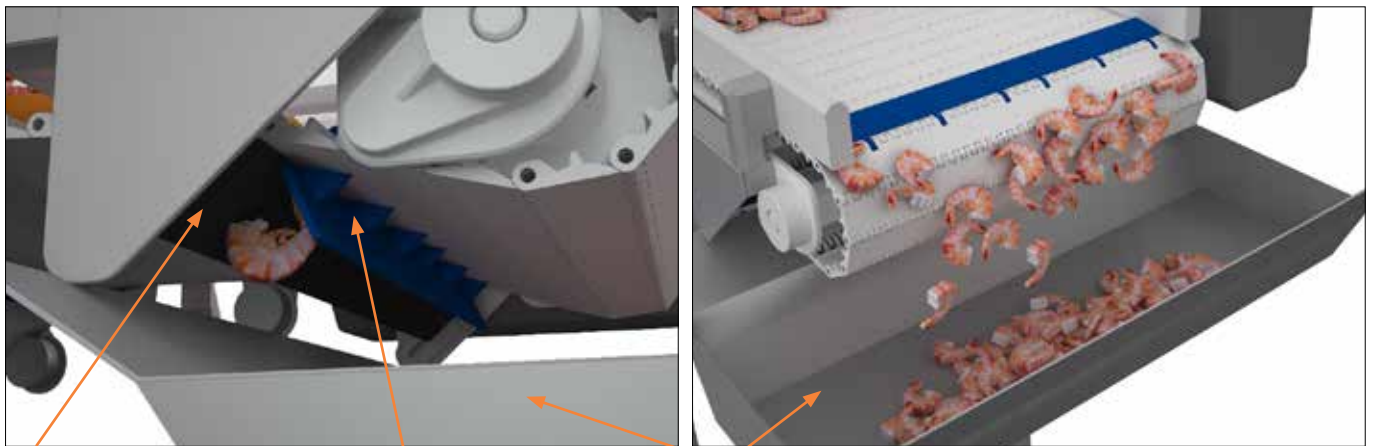

Scraper

Pop-up flight

Hopper

Driving the belt

Pop-up flight system is designed for single direction operation.

See diagrams on page 4 for correct Pop-up flight system travel direction.

System should be driven with MPB H single row sprockets. See table below for sprocket details.

We recommend drive systems are fitted with suitable automatic overload protection which should be adjusted and set to detect any system jamming or overloading. The drive system should automatically shut down if any mechanical jamming occurs.

Reversing of Pop-up flight systems should be avoided. Please contact Ammeraal Beltech before any such systems are constructed.

Standard sprocket sizes (min. 8 teeth):

No of teeth	Pilot bore	Bore size										Overall diameter		Pitch-diameter		Hub-diameter		A-dimension		B-dimension		Single row/One way	Molded	Machined
		in	0.75	0.79	0.98	1.00	1.18	1.25	1.50	1.57	2.36													
		mm	19.1	20.0	25.0	25.4	30.0	31.8	38.1	40.0	60.0	63.5	mm	in	mm	in	mm	in	mm	in				
Z08	x				●	●	●	■	■			132.9	5.23	132.8	5.23	65.0	2.56	53.3	2.10	74.9	2.95	x	x	
Z10	x					●	●	■	■			166.3	6.55	164.4	6.47	65.0	2.56	70.2	2.76	90.7	3.57	x	x	
Z10										■	■	166.3	6.55	164.4	6.47	120.0	4.72	70.2	2.76	90.7	3.57	x	x	
Z12	x					●	●	■	■	■	■	198.6	7.82	196.3	7.73	120.0	4.72	86.8	3.42	106.6	4.20	x	x	
Z16	x					●	●	■	■	■	■	263.8	10.39	260.4	10.25	150.0	5.91	119.7	4.71	138.7	5.46	x		x

■ Molded sprocket

● Molded sprocket

■ Machined sprocket

● Machined sprocket

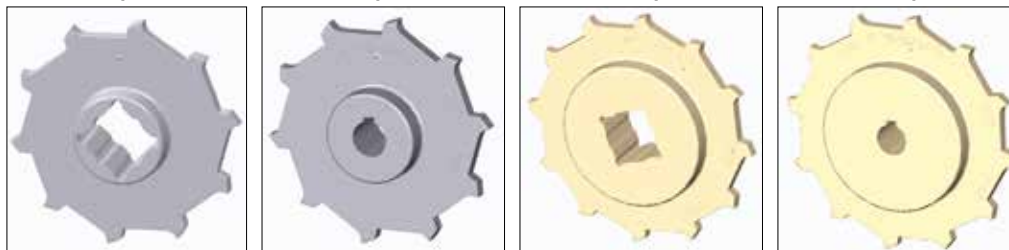

Non standard material and color: See uni Material and Color Overview.

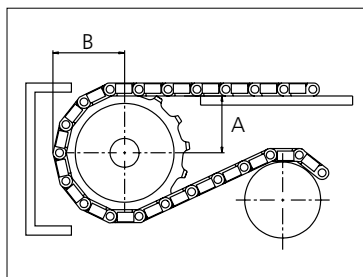

The maximum load per sprocket is 1250 N

Sprocket engagement

The single row one way sprockets must be placed as shown on below pictures which means that the idler sprocket must be installed mirrored to the drive sprockets.

The drive sprocket teeth must engage the hinge never on the center bar in the middle of the link and the idler sprocket must be driving by the hinge not by the center bar, see pictures below.

For further details please see belt assembly instructions sheet which can be downloaded from [here](#).

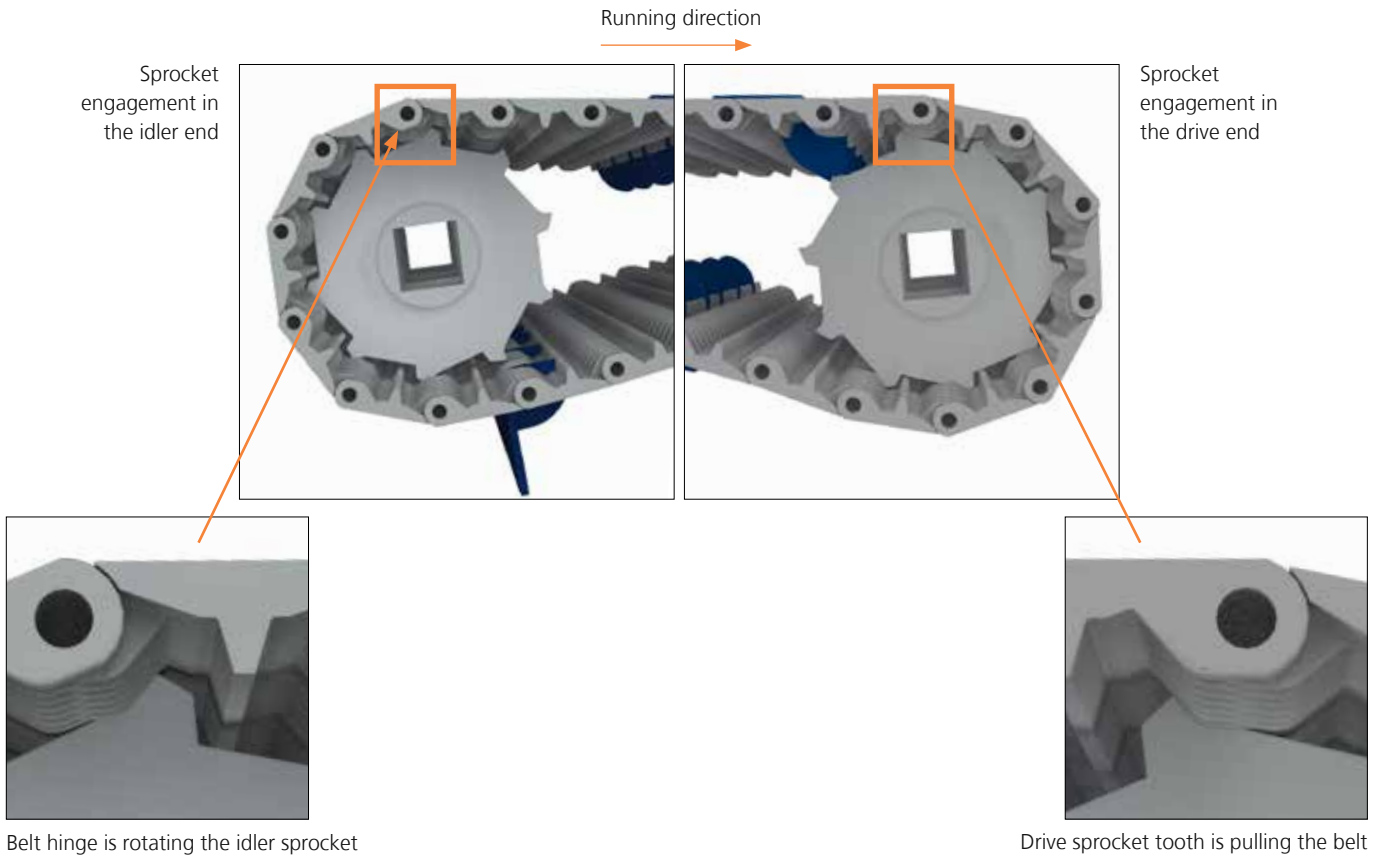

Retainer Rings

For belts wider than 604 mm (23.8 in) Ammeraal Beltech Modular A/S recommend to fix the center sprocket on each shaft with a uni Retainer Ring this fixed sprocket will be used for tracking the belt. All other sprockets must be able to move sideways to allow for dimensional changes, due to temperature.

For belts up to 604 mm (23.8 in) in width all sprockets can be fixed with uni Retainer Rings. This is an advantage if the belt is often removed as part of cleaning process because it will be easy to reinstall the belt again if all sprockets are fixed to the shaft. One disadvantage with the uni retainer ring is the cleanability the uni retainer Rings can be difficult to clean.

For placing of the sprockets please also see section *“Placing of activation and wear strip, plus drive and idler sprockets”*.

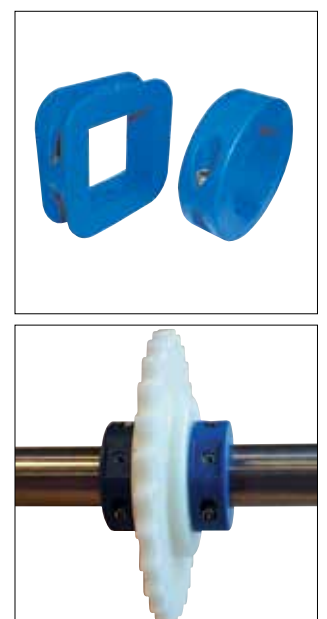

Guiding of the belt

The modular belt must be suitably guided and supported in both horizontal and vertical directions.

Sideways across the conveyor width the modular belt can either be edge guided by placing suitable wear-strips along each edge or guided by means of sprockets fixed to the shafts.

When the modular belt is edge guided, a running clearance should exist under all operating conditions. Any sliding contact should only be against the belt edges and not against the Pop-up flight, since any sideways contact with the Pop-up flight can prevent them lowering when deactivated. The distance between the guiding support and flight (C) must be larger than the distance from the belt to the conveyor frame (D). See sketch below.

When edge guiding the belt it is possible to leave all sprockets floating on the shafts since the sprockets will be guided by the belt position. When this system is used care must be taken when mounting the belt that sprocket positions do not interfere with the Pop-up flight activation cams.

An alternative set-up can be to fully track the belts sideways position by means of the sprockets.

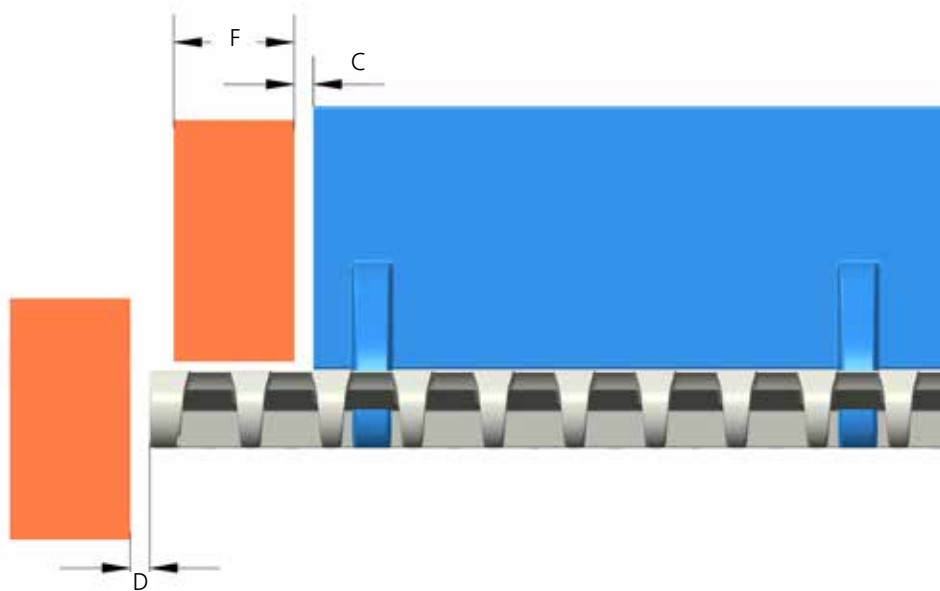

	mm	in
C	>D	>D
D	min 2.0	min 0.08
F	min 25.0	min 0.98

Hold down profiles

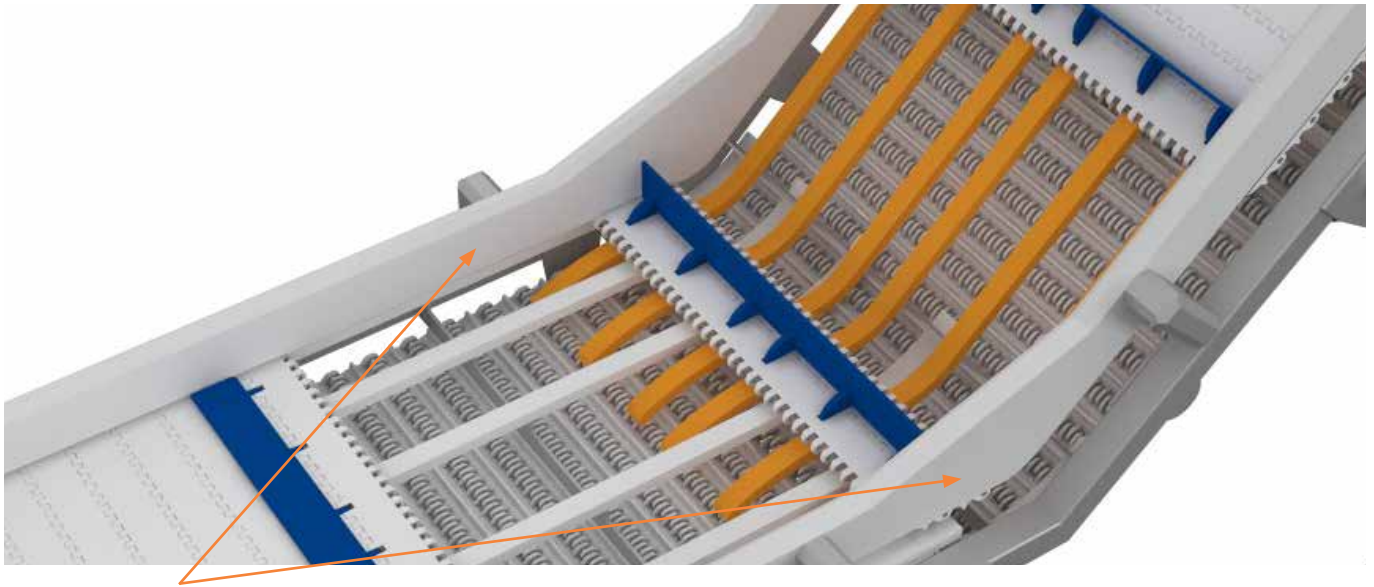

Hold down profiles

At the carry way, where the belt direction changes from being horizontal to being inclined, “hold downs” will be necessary to control of the belt. The hold down at the carry way will normally be a part of the side guide, but it can also be done by rollers or hold down shoes, depending of the conveyor design.

Return belt support

Ammeraal Beltech Modular A/S recommend the use of rotating return rollers at the edge of the belt. See drawing below.

Another option is wear strips at the edge but as with rotating return rollers at the edge you have to think about the beam stiffness.

On the return section the belt can be supported by return shoes, rollers or wear strips, like given on the drawing below. For wide belts the uni MPB Tab system, full width rollers or intermediate wear strips could be an option.

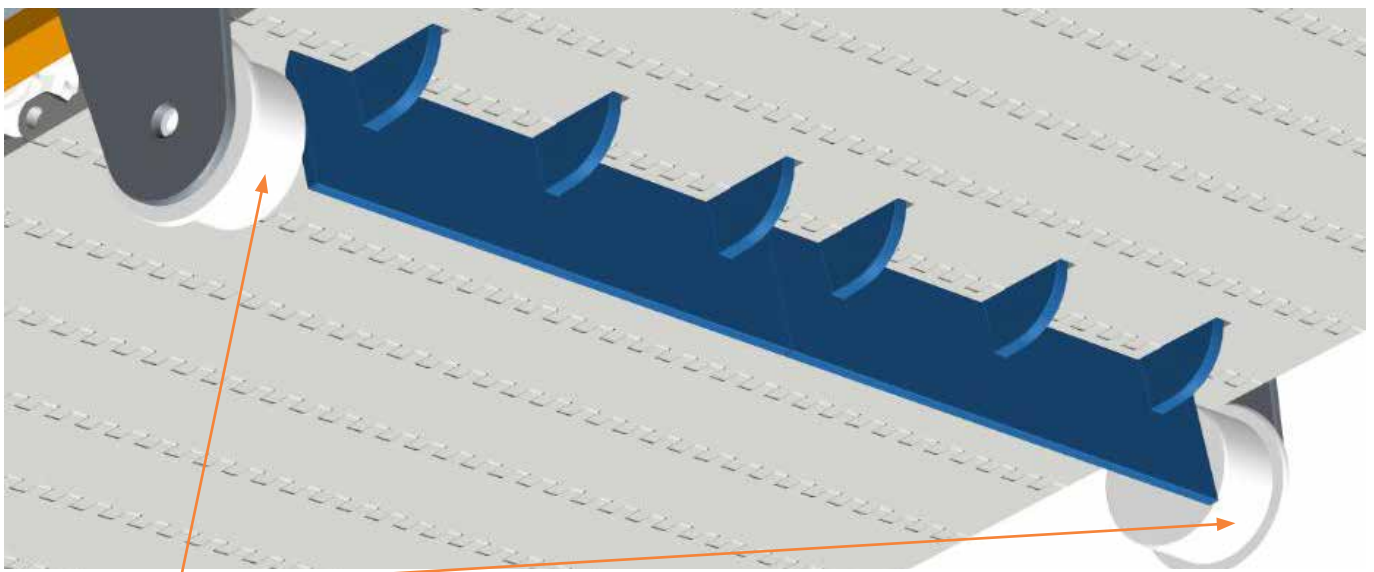

Rotating return rollers

Recommended belt sizes

Pop-up flights can be provided for all MPB belts above 202.0 mm (7.95 in) wide.

We offer a range of standard Pop-up flight configurations with 34.0 mm (1.34 in) indents as standard as show in bold text according to the table below. Other configurations are available upon request.

uni MPB belts with Pop-up flights up to 604.0 mm (23.8 in) in the width is always assembled with single links.

All uni MPB belts with Pop-up flights has as standard 34.0 mm (1.34 in) indent (i) to the Pop-up flight both sides to allow use of hold down wearstrips. The height of the Pop-up flight (H) is fixed to 54.8 mm (2.16 in).

Belts wider than 604 mm (23.8 in) will be constructed with a minimum number of modules across the width

To increase the belts beam strength stainless steel pins can be added. As standard for all belts above 604.0 mm (23.8 in) wide stainless steel pins are added every 5th link.

Please see below dimensional sketch of mounted Pop-up flight.

	mm	in
H	54.8	2.16
I	34.0	1.34
P	50.8	2.00
T	16.0	0.63

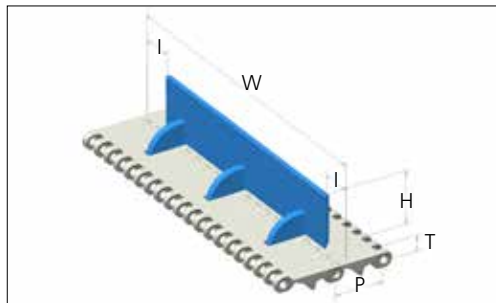

Recommended belt dimensions

Belt width (W)		Indents (I)		Flight width (B)		Belt width (W)		Indents (I)		Flight width (B)	
mm	in	mm	in	mm	in	mm	in	mm	in	mm	in
302	11.9	34	1.34	234	9.2	571	22.5	34	1.34	503	19.8
319	12.6	34	1.34	251	9.9	588	23.1	34	1.34	520	20.5
336	13.2	34	1.34	268	10.6	604	23.8	34	1.34	536	21.1
353	13.9	34	1.34	285	11.2	655	25.8	34	1.34	587	23.1
370	14.6	34	1.34	302	11.9	705	27.8	34	1.34	637	25.1
386	15.2	34	1.34	318	12.5	756	29.8	34	1.34	688	27.1
403	15.9	34	1.34	335	13.2	807	31.8	34	1.34	739	29.1
420	16.5	34	1.34	352	13.9	857	33.7	34	1.34	789	31.1
437	17.2	34	1.34	369	14.5	907	35.7	34	1.34	839	33.0
453	17.8	34	1.34	385	15.2	957	37.7	34	1.34	889	35.0
470	18.5	34	1.34	402	15.8	1008	39.7	34	1.34	940	37.0
487	19.2	34	1.34	419	16.5	1058	41.7	34	1.34	990	39.0
504	19.8	34	1.34	436	17.2	1109	43.7	34	1.34	1041	41.0
521	20.5	34	1.34	453	17.8	1159	45.6	34	1.34	1091	43.0
537	21.1	34	1.34	469	18.5	1209	47.6	34	1.34	1141	44.9
554	21.8	34	1.34	486	19.1	-	-	-	-	-	-

In the table above all possible belt and flight widths, up to 1209 mm (47.6 in) in belt width, are given.

Hold down tabs

If the Pop-up flight for some reason needs to cover the whole belt width (no indent), hold down tabs will be necessary. Hold down tabs are accessories that can be built into the uni MPB belts.

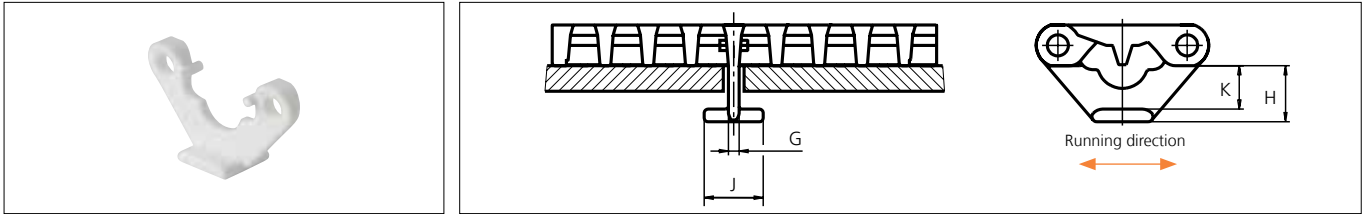

G		J		K		H	
mm	in	mm	in	mm	in	mm	in
4.2	0.17	23.2	0.91	17.0	0.67	22.0	0.87

Note: When using tabs, please verify sufficient clearance to the shaft. Maximum round shaft size can be calculated by using this formula:

$$\text{Max. round shaft diameter} = \text{Sprocket pitch diameter} - 76.2 \text{ mm (3.00 in)}$$

Example: Sprocket Z = 8:

$$\text{Maximum round shaft diameter} = 132.8 - 76.2 = 56.6 \text{ mm (2.23 in)}$$

Placing of activation and wear strips, plus drive and idler sprockets

The placing of activation strips and sprockets is critical. To get the best possible flight support the activation strips must be placed directly beneath the each cam on the Pop-up flight. To avoid collisions with sprockets and cams, the sprockets must be placed as close to the center between the activation strips as possible.

Wear strips at areas where the Pop-up flight is deactivated can be placed at the outer edged and in line with the sprockets, like give on the drawing below.

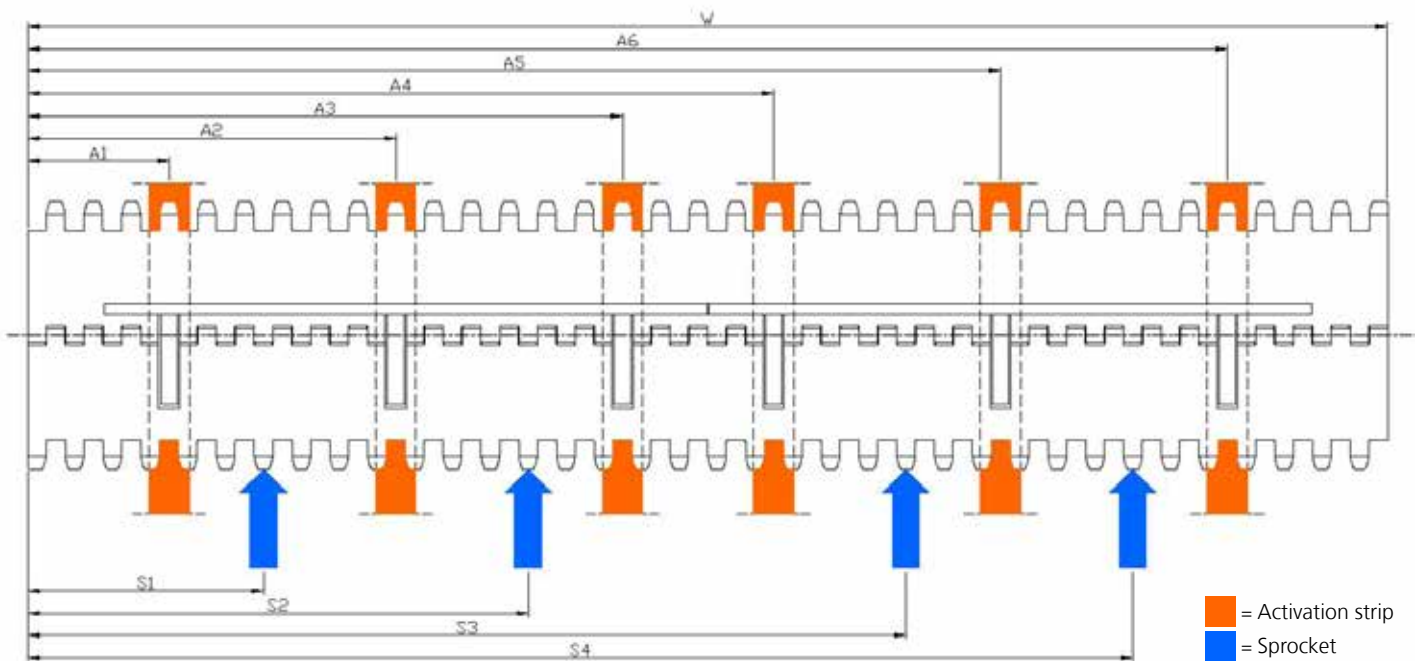

The width of both the activation and wear strips are recommended to be minimum 25 mm.

Positions of activation strips

The recommend positions of the activation strips are given in the table below.

(A-dimension are only valid for standard 34 mm (1.34 in) indent both sides to the Pop-up flight.)

Placing of activation wearstrips																											
Belt width (W)		Activation wearstrips																									
		Distance from belt left hand edge to center of activation wearstrip																									
		A1		A2		A3		A4		A5		A6		A7		A8		A9		A10		A11		A12		A13	
mm	in	mm	in	mm	in	mm	in	mm	in	mm	in	mm	in	mm	in	mm	in	mm	in	mm	in	mm	in	mm	in	mm	in
302	11.9	46	1.8	147	5.8	248	9.8																				
319	12.6	63	2.5	164	6.5	265	10.4																				
336	13.2	63	2.5	164	6.5	265	10.4																				
353	13.9	63	2.5	164	6.5	197	7.8	298	11.7																		
370	14.6	63	2.5	164	6.5	197	7.8	298	11.7																		
386	15.2	63	2.5	164	6.5	214	8.4	315	12.4																		
403	15.9	63	2.5	164	6.5	231	9.1	332	13.1																		
420	16.5	63	2.5	164	6.5	248	9.8	349	13.7																		
437	17.2	46	1.8	147	5.8	248	9.8	298	11.7	382	15.0																
453	17.8	46	1.8	147	5.8	248	9.8	298	11.7	399	15.7																
470	18.5	63	2.5	164	6.5	265	10.4	298	11.7	399	15.7																
487	19.2	63	2.5	164	6.5	265	10.4	315	12.4	416	16.4																
504	19.8	63	2.5	164	6.5	265	10.4	332	13.1	433	17.0																
521	20.5	63	2.5	164	6.5	265	10.4	322	12.7	433	17.0																
537	21.1	63	2.5	164	6.5	265	10.4	365	14.4	466	18.3																
554	21.8	63	2.48	164	6.46	265	10.4	298	11.7	399	15.7	500	19.8														
571	22.5	63	2.5	164	6.5	265	10.4	315	12.4	416	16.4	517	20.4														
588	23.1	63	2.5	164	6.5	265	10.4	332	13.1	433	17.0	533	21.0														
604	23.8	63	2.5	164	6.5	265	10.4	332	13.1	433	17.0	533	21.0														
655	25.8	63	2.5	164	6.5	214	8.4	315	12.4	416	16.4	483	19.0	584	23.0												
705	27.8	63	2.5	164	6.5	248	9.8	349	13.7	449	17.7	536	21.1	634	25.0												
756	29.8	63	2.5	164	6.5	265	10.4	315	12.4	416	16.4	517	20.4	584	23.0	685	27.0										
807	31.8	63	2.5	164	6.5	265	10.4	298	11.7	399	15.7	500	19.7	533	21.0	634	25.0	735	28.9								
857	33.7	63	2.5	164	6.5	265	10.4	332	13.1	433	17.0	533	21.0	584	23.0	685	27.0	785	30.9								
907	35.7	63	2.5	164	6.5	265	10.4	332	13.1	433	17.0	466	18.3	567	22.3	634	25.0	735	28.9	836	32.9						
957	37.7	63	2.5	164	6.5	265	10.4	332	13.1	433	17.0	517	20.4	617	24.3	685	27.0	785	30.9	886	34.9						
1008	39.7	63	2.5	164	6.5	265	10.4	332	13.1	433	17.0	533	21.0	584	23.0	685	27.0	735	28.9	836	32.9	937	36.9				
1058	41.7	63	2.5	164	6.5	265	10.4	332	13.1	433	17.0	533	21.0	617	24.3	718	28.3	785	30.9	886	34.9	987	38.9				
1109	43.7	63	2.5	164	6.5	265	10.4	332	13.1	433	17.0	533	21.0	584	23.0	685	27.0	785	30.9	836	32.9	937	36.9	1037	40.8		
1159	45.6	63	2.5	164	6.5	265	10.4	332	13.1	433	17.0	483	19.0	584	23.0	685	27.0	735	28.9	836	32.9	886	34.9	987	38.9	1088	42.8
1209	47.6	63	2.5	164	6.5	265	10.4	332	13.1	433	17.0	500	19.7	601	23.7	701	27.6	786	30.9	869	34.2	936	36.9	1037	40.8	1138	44.8

Positions of sprockets

The recommend positions of drive/idler sprockets are given in the table below.

(S-dimension are only valid for standard 34.0 mm (1.34 in) indent both sides to the Pop-up flight.)

Placing of activation wearstrips																		
Belt width (W)		Min. No drive sprockets	Sprocket Position															
			Distance from belt left hand edge to center of sprocket															
mm	in	Ea	S1		S2		S3		S4		S5		S6		S7		S8	
mm	in	Ea	mm	in	mm	in	mm	in	mm	in	mm	in	mm	in	mm	in	mm	in
302	11.9	2	88	3.5	206	8.1												
319	12.6	2	105	4.1	226	8.9												
336	13.2	2	105	4.1	226	8.9												
353	13.9	2	105	4.1	256	10.1												
370	14.6	2	105	4.1	256	10.1												
386	15.2	2	105	4.1	273	10.7												
403	15.9	2	105	4.1	290	11.4												
420	16.5	3	105	4.1	206	8.1	307	12.1										
437	17.2	3	88	3.5	206	8.1	340	13.4										
453	17.8	3	88	3.5	206	8.1	357	14.1										
470	18.5	3	105	4.1	223	8.8	357	14.1										
487	19.2	3	105	4.1	223	8.8	374	14.7										
504	19.8	3	105	4.1	223	8.8	391	15.4										
521	20.5	3	105	4.1	223	8.8	391	15.4										
537	21.1	4	105	4.1	223	8.8	323	12.7	424	16.7								
554	21.8	4	105	4.1	223	8.8	357	14.7	457	18.0								
571	22.5	4	105	4.1	223	8.8	357	14.7	475	18.7								
588	23.1	4	105	4.1	223	8.8	374	14.7	491	19.3								
604	23.8	4	105	4.1	223	8.8	374	14.7	491	19.3								
655	25.8	4	105	4.1	256	10.1	374	14.7	542	21.3								
705	27.8	4	105	4.1	290	11.4	407	16.0	592	23.3								
756	29.8	5	105	4.1	223	8.8	357	14.1	475	18.7	643	25.3						
807	31.8	6	105	4.1	223	8.8	340	13.4	458	18.0	575	22.6	693	27.3				
857	33.7	6	105	4.1	223	8.8	374	14.7	491	19.3	626	24.6	743	29.3				
907	35.7	6	105	4.1	223	8.8	374	14.7	525	20.7	676	26.6	794	31.3				
957	37.7	6	105	4.1	223	8.8	374	14.7	575	22.6	727	28.6	844	33.2				
1008	39.7	7	105	4.1	223	8.8	374	14.7	491	19.3	643	25.3	777	30.6	895	35.2		
1058	41.7	7	105	4.1	223	8.8	374	14.7	491	19.3	676	26.6	827	32.6	945	37.2		
1109	43.7	8	105	4.1	223	8.8	374	14.7	491	19.3	626	24.6	743	29.3	878	34.6	995	39.2
1159	45.6	8	105	4.1	223	8.8	374	14.7	525	20.7	643	25.3	794	31.3	928	36.5	1046	41.2
1209	47.6	8	105	4.1	223	8.8	374	14.7	542	21.3	659	25.9	827	32.6	978	38.5	1096	43.1

Materials for the Pop-up flight system

The Pop-up flight system is standard in the following materials:

PP-I

- Polypropylene with improved impact resistance compared to ordinary PP
- Application temperature -10°C to 80°C (the impact strength will be reduced significantly below 0°C)
- Colour options in blue and white

PE-I

- Polyethylene with very high impact strength, even at low temperatures
- Application temperature -50°C to 80°C
- Colour options in blue and natural
- Polyethylene has a natural non-stick characteristic

It is recommended to configure homogeneous belts, i.e. flights, links and pins in the same material.

Both polyethylene and polypropylene have a very good resistance towards most detergents and disinfection products.

PP-I is recommended for applications above 0°C.

The tensile strength of PP-I is 23% higher than it is for PE-I.

PE-I is recommended for application below 0°C and where very high impact resistance is required.

For abrasive applications with grain formed wear (salt, sugar, etc.) a PE-I belt/flight together with wear strips made of a harder material will be preferable.

Further support

For any further support, please consult our technical support staff at your local Ammeraal Beltech office. Please see details of contact on the rear side of this guide.

Also you can find more engineering guide lines in our general purpose Engineering Manual, which you will find at www.unichains.com

Local Contacts

Australia

T +61 3 9555 7922
info-au@ammeraalbeltech.com
www.rydell.com.au

Austria

T +43 171728 133
info-de@ammeraalbeltech.com
www.ammeraalbeltech.at

Belgium

T +32 2 466 03 00
info-be@ammeraalbeltech.com
www.ammeraalbeltech.be

Canada

T +1 905 890 1311
info-ca@ammeraalbeltech.com
www.ammeraalbeltech.com

Chile

T +56 2 233 12900
info-cl@ammeraalbeltech.com
www.ammeraalbeltech.cl

China

T +86 512 8287 2709
info-cn@ammeraalbeltech.com
www.ammeraalbeltech.com.cn

Czech Republic

T +420 567 117 211
info-cz@ammeraalbeltech.com
www.ammeraalbeltech.cz

Finland

T +358 207 911 400
info-fi@ammeraalbeltech.com
www.ammeraalbeltech.fi

France

T +33 3 20 90 36 00
info-fr@ammeraalbeltech.com
www.ammeraalbeltech.fr

Germany

T +49 4152 937-0
info-de@ammeraalbeltech.com
www.ammeraalbeltech.de

Hungary

T +36 30 311 6099
info-hu@ammeraalbeltech.com
www.ammeraalbeltech.hu

India

T +91 44 265 34 244
info-in@ammeraalbeltech.com
www.ammeraalbeltech.com

Italy

T +39 051 660 60 06
info-it@ammeraalbeltech.com
www.ammeraalbeltech.it

Luxembourg

T +352 26 48 38 56
info-lu@ammeraalbeltech.com
www.ammeraal-beltech.lu

Malaysia

T +60 3 806 188 49
info-my@ammeraalbeltech.com
www.ammeraalbeltech.com

Netherlands

T +31 72 57 51212
info-nl@ammeraalbeltech.com
www.ammeraalbeltech.nl

Poland

T +48 32 44 77 179
info-pl@ammeraalbeltech.com
www.ammeraalbeltech.com

Portugal

T +351 22 947 94 40
info-pt@ammeraalbeltech.com
www.ammeraalbeltech.pt

Singapore

T +65 62739767
info-sg@ammeraalbeltech.com
www.ammeraalbeltech.com

Slovakia

T +421 2 55648541-2
info-sk@ammeraalbeltech.com
www.ammeraalbeltech.sk

South Korea

T +82 31 448 3613-7
info-kr@ammeraalbeltech.com
www.ammeraalbeltech.co.kr

Spain

T +34 93 718 3054
info-es@ammeraalbeltech.com
www.ammeraalbeltech.es

Sweden

T +46 44 780 3010
info-se@ammeraalbeltech.com
www.ammeraalbeltech.se

Switzerland

T +41 55 2253 535
info-ch@ammeraalbeltech.com
www.ammeraalbeltech.ch

Thailand

T +66 2 902 2604-13
info-th@ammeraalbeltech.com
www.ammeraalbeltech.com

United Kingdom

T +44 1992 500550
info-uk@ammeraalbeltech.com
www.ammeraalbeltech.co.uk

United States

T +1 847 673 6720
info-us@ammeraalbeltech.com
www.ammeraalbeltech.com

Vietnam

T +84 8 376 562 05
info-vn@ammeraalbeltech.com
www.ammeraalbeltech.com.vn

Global Headquarters:

Ammeraal Beltech Holding B.V.
P.O. Box 38
1700 AA Heerhugowaard
The Netherlands

T +31 (0)72 575 1212
F +31 (0)72 571 6455

info@ammeraalbeltech.com
www.ammeraalbeltech.com

**Expert advice, quality solutions
and local service
for all your belting needs**

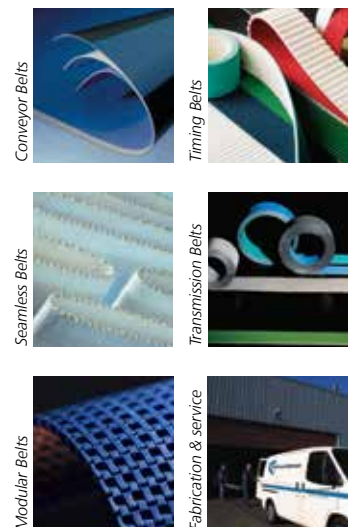

... and 150 more service contact points at www.ammeraalbeltech.com